



## Oregon Shakespeare Festival's The Green Show

<http://osfashland.org/greenshow>

### Submission Guidelines

“Collaboration, Community, and Commitment: a commitment to access and excellence!”

We are looking for a diverse variety of performance groups and individual artists. There are several ways to participate in the upcoming season. You can participate as an **individual performer/group** (e.g., a vocalist or an improvisation troupe) or you can participate as a **programmer**. Programmers offer a number of different performers under one theme, and would be responsible for compensating and managing their performers themselves (e.g., “The Jazz Club presents guests artists from its own season” or “Sue’s 6 different acts”). **Each performance is 35-40 minutes in length.** You can perform on **consecutive** dates (e.g., three days in a row) or perform **alternating** dates throughout the season (e.g., every other Tuesday and Thursday for three weeks). We also will have limited opportunities to offer educational workshops to the community and/or the company.

This is a curated show with a commitment to excellence, access, and opportunity. This means we will be programming with the goals of balance, diversity, and high quality performance throughout each week. OSF wants the best. We will also be programming with thoughts of resonance with the communities of our audience and our plays on stage. This means shows can be a variety of different genres but must be appropriate for a number of different audiences. Visit our website to study the plays of the 2009 season to see if any of your work has resonance with the production concepts. Visit <http://eq.tv> to see examples of past performances we have programmed. Please keep in mind that we might be unable to program you this season due to scheduling constraints so do not take a lack of response as a sign of the quality of your submission. Due to the number of submissions we will be unable to contact everyone individually, but send questions and comments to [greenshow@osfashland.org](mailto:greenshow@osfashland.org) and we will respond as we are able. Looking forward to making art with you!

Claudia Alick  
Associate Producer, community

## Oregon Shakespeare Festival's The Green Show

<http://osflashland.org/greenshow>

### Submission Guidelines

#### Stage Dimensions:

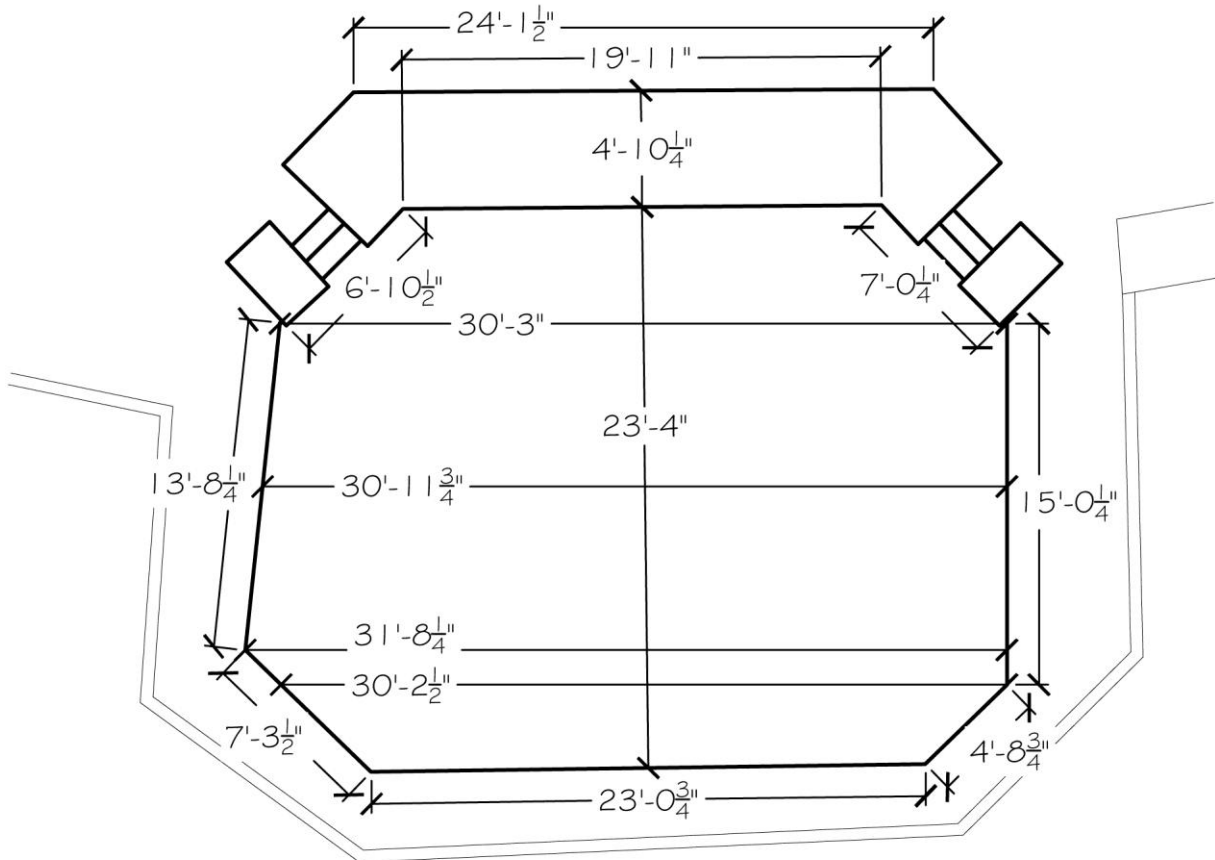

Green Show Deck

Scale: 1/8" = 1'0"

**Technical Note:** This is an outdoor performance space without lighting. We provide stage hands, a production coordinator, and a sound engineer. We also provide Mixers, Microphones (handheld and wireless), Keyboards, Music stands, Monitors, and minimal stage dressing. Contact us with specific questions regarding sound equipment. Please keep technical and set requirements to a minimum. There is no "backstage" but the space behind the stage can be used for crossover.